

MODIFYING THE FT-7: (Part 1 of 2) Turn a Good Radio into a Great QRP Radio

by Phil Salas AD5X
1517 Creekside Drive
Richardson, Texas 75081
packet: @N5LDD,#NTX.TX.USA.NA.

INTRODUCTION

My favorite QRP rig (of the several I own) is a Yaesu FT-7. Virtually all of the circuitry in this radio is on separate plug-in cards making it easy to get to and modify. All the adjustments are easily accessible and the radio has a terrific receiver. And, since these are mid-70s vintage radios, the price is reasonable when you can find someone who wants to part with one. However, there are several modifications that can be made to this radio to really improve its performance and operating convenience.

MODIFICATIONS/ADJUSTMENTS

The FT-7 is rated at 20 watts input, 10 watts PEP and CW output. My FT-7 put out 16 watts so some adjustments were in order to get to the QRP levels. First, I adjusted the maximum output to 10 watts CW and PEP. This is easily done by keying the transmitter in the CW mode and adjusting the ALC control (VR1501 on the back of the radio by the key jack—see the instruction book) such that you are at the 10 watt level as measured on a wattmeter. The FT-7 should be connected to a resistive 50 ohm dummy load for these power measurements.

The FT-7 now puts out 10 watts PEP and CW but you need to be at 5 watts maximum for CW QRP. You could adjust the ALC for 5 watts for both CW and SSB but I chose to keep the SSB PEP at the maximum 10 watt QRP level and adjust the CW output separately. This is easily done through a simple modification of the IF unit. The IF unit contains a separate 8999.3 KHz crystal controlled oscillator for CW transmit. The frequency gives you the 700 Hz offset necessary for CW. To give a CW drive control, I replaced R421 (10K resistor on the gate of Q404) with a 10K multi-turn potentiometer as shown in the before and after schematics (Figures 1 and 2). I epoxied the 10K potentiometer to the IF unit pc board as close to Q404 as possible. I also replaced several stand-up resistors and large disk capacitors with smaller units so that I would have room for this potentiometer and be able to adjust it when the unit was plugged in place.

I found that the FT-7 gain through the transmitter varies slightly as a function of the band used. The gain is highest on 20 meters, and lowest on 80 and 10 meters. Therefore, I set the potentiometer for 5 watts output on 20 meters. With this setting, I wound up with 3 watts output on 80 and 10 meters. I made one

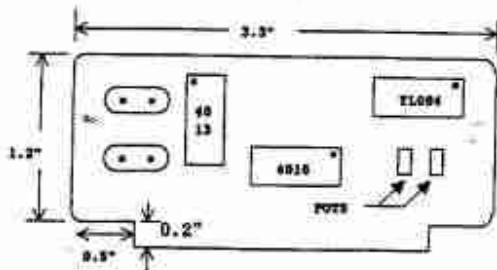

FIGURE 2
FILTER/SWITCHER BOARD LAYOUT

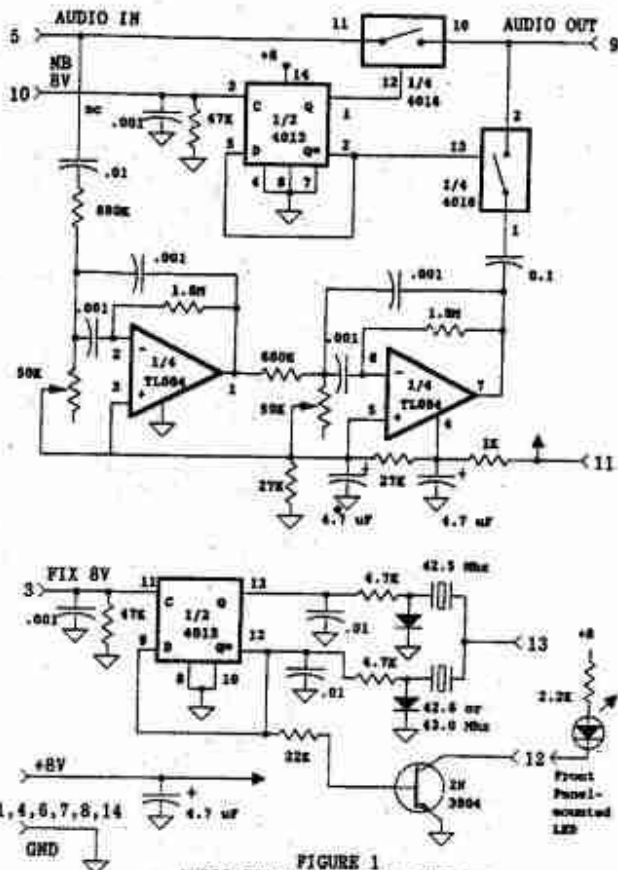

FIGURE 1
AUDIO FILTER/CRYSTAL SWITCHER

more modification to this board. You can vary the 8999.3 kHz frequency quite a bit with the crystal oscillator tuning capacitor. The FT-7 manual tells you to adjust this capacitor for a given output LEVEL. When I did this, I found that the crystal could be off frequency by several hundred Hz, yielding the wrong CW transmit offset. As it is very difficult to measure this frequency, I modified the board to bring the output to pins on the top of the board where I could easily connect my trusty frequency counter. I used a piece of shielded audio wire connected to the anode of D402 and ran it to the top of the board. For the test pins, I drilled two small holes in the board and soldered two small nails to the ground plane. Then I cut away the ground plane around the nail I was using for the center conductor connection of the cable. (A Teflon standoff post eliminates the need for ground plane "surgery" -NNIG)

Now I was easily able to adjust the crystal oscillator frequency for exactly 8999.3 kHz.

CONCLUSION

With some fairly easy modifications, you can turn the Yaesu FT-7 into an excellent CW QRP rig. In the next installment, we'll add crystal switching to extend 10 meter coverage, as well as a variety of other useful features.

YAESU FT-7 MODIFICATIONS TURN A GOOD RADIO INTO A GREAT QRP RADIO (Part 2 of 2)

Phil Salas AD5X
1517 Creekside Drive
Richardson, Texas 75081

(I inadvertently ran Figures 1 and 2 for this installment in part 1 (Jan. '94 issue). To prove that "two wrongs don't make a right", we're running the part 1 illustrations right here in part 2. Color me embarrassed! - NN1G)

This article modifies the FT-7 to add a number of useful features and makes it a great radio. Each of the changes uses an existing front-panel control to switch these options in and out, eliminating the need to drill holes and add switches. Flip-flops provide click-on/click-off operation- an easy way to extend front-panel functionality.

AUDIO CW FILTER AND 10 METER CRYSTAL SWITCH

Unfortunately, the FT-7 has no provisions for a CW filter and the SSB filter is just too wide for serious CW operating. Also, the FT-7 has provisions for only a single 500 Khz portion of the 10 Meter band. Fortunately, however, the FT-7 has a fixed crystal plug-in board which gives you the capability of operating on one crystal controlled frequency per band. I replaced that board with one made from a piece of Radio Shack 44-pin edge connector perf board (RS 276-154 @ \$3.49). This board can be cut to fit the FT-7 fixed crystal board. Just use the FT-7 fixed crystal board as a template to create an outline on the Radio Shack board and carefully cut it out with a coping- or band-saw. After you've cut out this board, tin the edge connector using a small iron and minimal solder. Use copper braid (from a piece of coax) to wick off excess solder.

The complete circuit is shown in Figure 1 and the component layout I used is shown in Figure 2 (see the Jan '94 issue). This is a popular 2-pole bandpass filter with a 200 Hz bandwidth that has been published previously in some ARRL publications. I replaced the

fixed 24K frequency-determining resistors in the original article with the two 50K multi-turn pots to be able to adjust the filter center (TX offset) frequency. This is 700 Hz for the FT-7. The active filter uses a TL084 JFET op-amp. One section of the 4013 dual D flip flop is used to switch the filter in and out of the circuit with the help of the 4016 quad analog switch. The other section of the flip flop is used to select between the two 10-meter crystals. For the HC-25U crystal sockets, I just removed two sockets from the original "fixed" board. Also, instead of the 43.0 Mhz crystal for the "high" 10 meter band, I used a 42.8 Mhz crystal to cover 28.3-28.8 Mhz. This provides me with one crystal for CW and one for phone.

Now you need to re-wire the "fixed" connector on the FT-7 main board. Turn the FT-7 over and remove the bottom cover. Unsolder all the wires from the band switch that go to this connector. Find a source of regulated +8 volts and solder a wire from this source to pin 11 of the "fixed" connector. There is a small sub-board mounted just above the "fixed" connector that has +8 volts available on it all the time (right-most post on the sub-board as you look at the bottom of the FT7 with the front panel on the right). Pin 14 of the "fixed" connector is the pin closest to you. Connect a shielded wire from pin 13 to the 10 meter crystal socket on the main board. Solder a shielded wire from pin 9 and a shielded wire from pin 5 (shields soldered to ground) that are long enough to reach pin 11 of the audio board. Disconnect the red wire currently soldered to pin 11 of the audio board. Solder the center conductor of the shielded cable coming from "fixed" connector pin 5 to the red wire just unsoldered from the audio board pin 11. Solder the center conductor of the shielded cable from "fixed" connector pin 9 to the audio board pin 11 and solder the shields to an adjacent ground.

To actually do the switching, I wired the filter's flip flop input to the USB/LSB/CW switch such that I go to a +8 volt input to the flip flop when switching from LSB to USB. I

wired the Noise Blanker/Off switch to the crystal flip flop input such that I get a +8 volt input when switching from OFF to NOISE BLANKER. To do this, move the wire from the FIX front panel switch (which goes to pin 3 of the "fixed" connector) to the NB switch (move the wire one solder terminal over - use a voltmeter to make sure you have the right switch connection). Add a wire from the USB/LSB/CW switch to the "fixed" connector pin 10. The switch terminal is the second from the bottom closest to the side of the radio. Again, use a voltmeter to make sure you are on the right switch position. Now you can toggle the CW filter in and out with the USB/LSB switch, and change 10 meter crystals with the NB/OFF switch. I also drilled a small hole in the front panel of the FT-7 and installed a red LED by the 10 meter position. The LED is lit when the switch is in the 10 meter "high" frequency position. You can easily hear when the audio filter is in or out so I didn't include an indicator for the filter. The radio will turn on with the CW filter out if the USB/LSB/CW switch is in the LSB or CW position. Also, the crystal plugged into the non-LED socket will be selected when the radio is turned on.

CURRENT REDUCTION

The FT-7 draws around 500 ma in receive. About 250 mA of this is just in the dial and meter lamps! I added 27 ohm resistors (1/2 watt required) in series with the Meter and Dial lamps, and 47 ohm resistors in series with the Clarifier and FIX lamps and saved 40 ma. This should also significantly increase the life of the lamps. Reducing the current much more than this caused the meter and dial to be difficult to read. Since I run off batteries

during portable operation, I decided that a means to switch off the dial lamps would also be worthwhile. Turning off these lamps reduces the receive drain to about 250 ma. In order to do this, I built another flip-flop controlled circuit (see Figure 3). Because I didn't have any more room on the "fixed" board, I used a 1-1/2" X 1-1/2" piece of perf board. I mounted this board to the chassis wall on the bottom side of the radio near the "fixed" connector with double sided sticky tape plus a blob of hot glue to ensure it wouldn't come loose. Next I unsoldered the ground pins and wires on the dial and meter lamps and attached the transistor output to these points. I connected the flip flop input to the "FIX" switch such that when you switch to the "FIX" position, you'll get +8 volts on this line. When wired as shown, the radio comes on with the lamps on. If you want it the other way, move the 4.7K TIP-120 base resistor from pin 1 to pin 2 of the 4013. Now you can toggle the lamps on and off by switching to the "FIX" position and back.

CONCLUSION

There you have it! With these modifications, you can turn the Yaesu FT-7 into an excellent CW QRP rig. It was already an great SSB rig. Adding crystal switching to give you the first 1 Mhz coverage of 10 meters also gives you most of the 10 meter action. Finally, you don't have to add obvious add-on switches to be able to add these features. I hope you can find an FT-7 before all their present owners read this article. Once someone installs these modifications in their FT-7, I doubt if they'll ever want to part with it!

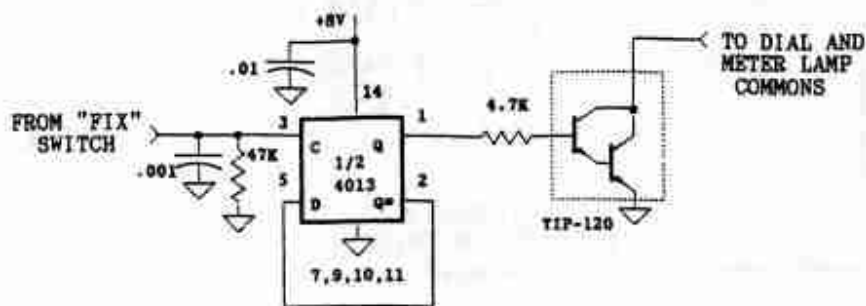
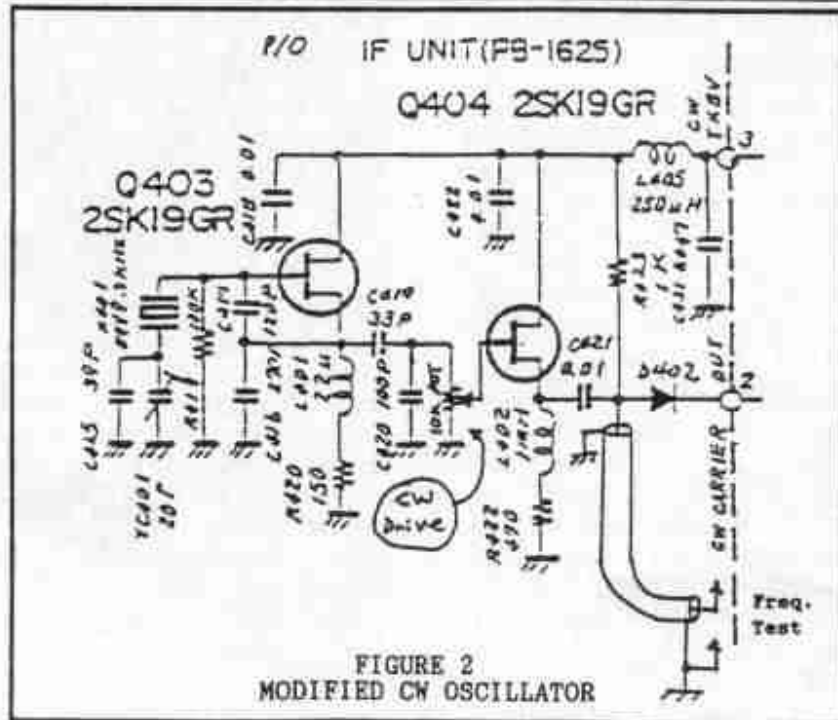
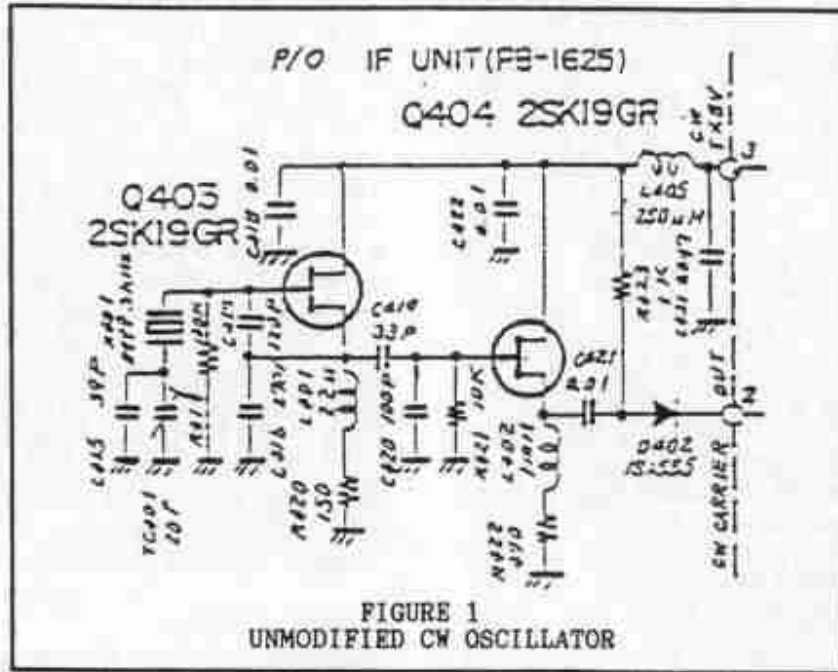

FIGURE 3
LAMP SWITCHER CIRCUIT

Yaesu FT-7 Modifications Turn a Good Radio into a Great QRP Radio - AD5X

(Here are Figures 1 and 2 which should have accompanied part 1 of Phil's article in the January '94 Quarterly.)



FILTER SWITCHING CIRCUIT FOR YOUR FT-7

From Phil Salas, AD5X of Richardson, TX--In the January and July 1994 QRP Quarterly I showed how to use flip-flops, analog switches, and transistors to toggle off and on internal circuits in your ham gear (primarily the FT-7) without having to add extra switches to your equipment. [The schematics got shuffled up a bit; consult both articles to get all the details. --WA8MCQ] The circuit in Figure 4 extends this to relay switching of CW and SSB crystal filters. In my earlier article, I switched an audio CW filter in and out. Unfortunately, the AGC pumping due to an "in-the-IF passband" signal often makes working weaker CW stations a problem when the band is crowded.

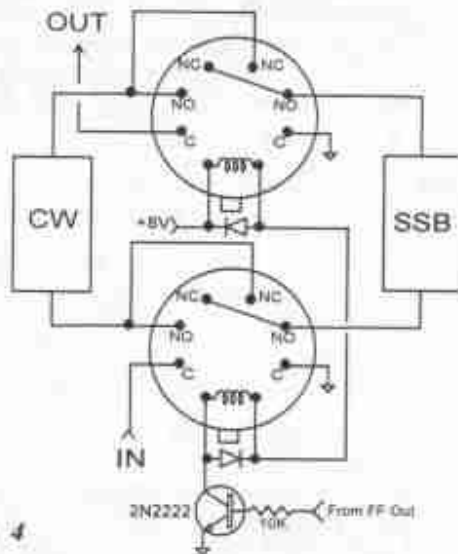

Figure 4

The only way around this problem is to add good selectivity with a CW crystal filter. International Radio & Computer, Inc (3804 South US #1, Fort Pierce, FL 34983 407-489-0956) sells a 500 Hz CW filter for the FT-7 for \$75 +\$6 S/H. I was able to mount this filter on the current FT-7 IF filter board along with the original SSB filter. I did this by clearing room on the board by moving several components from the top side of the pc board to the bottom side (see the attached photo, Fig. 5). Both filters and all the switching circuitry fit without too much problem. The new CW filter is mounted sideways on double sided sticky tape (Radio Shack) and the case of the filter is soldered to the cases of the transformers next to it with short pieces of wire.



Figure 5

I originally selected the filters with a single DPDT relay, but found that the relay isolation was poor enough that some signal was getting through the open relay contacts and the non-selected filter. I measured this leakage at around 40 dB, and believe-it-or-not, this is enough leakage to hear opposite sideband stuff! The circuit shown uses two DPDT relays and shorts out the unused filter relay contacts instead of leaving them open. This completely solves the problem. The relays I used were two 6 VDC miniature metal can surplus relays with their coils wired in series. They work fine on the 8 volt internal FT-7 power supply. Don't forget the diodes across the relay coils!

I went ahead and left the audio filter described in my earlier article in line as it helps remove some high frequency audio stage noise as well as provides some additional audio selectivity.

I keep making my FT-7 better and better. Now, how do I get the WARC bands?

--DE AD5X

HIGH-Z HEADPHONE COMMENTS

From one of the Great Masters of QRP, W9SCH, Rock of Albany, WI--John Collins, KN1H, had some interesting material on old headphones in a recent Idea Exchange (reprinted from the New England QRP newsletter).

As he shows, these commonly despised "antiques" may be interesting devices and often remarkably sensitive. Indeed, for amateur CW reception, a good pair of old magnetic phones will put these modern stereo headsets deep in the shade for sensitivity. Also, usually having an impedance on the order of ten kilohms and a DC resistance of 2K, they work well directly in the collector circuit of a small transistor. Because their audio frequency response usually peaks between 500 and 1500 Hz, they are highly effective for CW reception.

Some years ago I ran an informal sensitivity check upon some phones I own with the following results, the test being made at 400 Hz, the only AF signal at my disposal. To produce a barely useful response, an old, abused pair of "Brandes" phones required 1.1 microamps. A 1960 pair of "Trimm Dependables" required but 0.37 microamps, but the star performance was observed with a pair of "Nathaniel Baldwins" (called "baldies" in the old days), made around 1924. These produced a useful response with only 0.08 microamps, having mica diaphragms connected by lever action to the magnetic system.

The manufacturer claimed that this was equivalent to one stage of amplification or a gain of about ten decibels. So, if you have a pair of these phones, hang on to them--they're still a good deal.

Back in the Old Days, Hugo Gernsback described an interesting, simple test for the practical sensitivity of a pair of headphones. Wet the tips of the cords slightly and touch these together. A sensitive pair will respond with an audible click. He claimed that the voltage generated by the damp metal tips was less than 0.001 volt and the current less than 1 microampere. Be this correct or not, the Trimm and Baldwin phones passed the test easily, the Brandes slightly. This is still a handy test and I pass it along for what it is worth. Try it with your pair.

--DE W9SCH